

## DevKit8000 Evaluation Kit

- *TI OMAP3530 Processor based on 600MHz ARM Cortex-A8 core*
- *Memory supporting 256MByte DDR SDRAM and 256MByte NAND Flash*
- *UART, USB Host/OTG, Ethernet, Camera, Audio, SD, Keyboard, Jtag,...*
- *Supports 24-bit TFT LCD, DVI-D and TV S-Video Output Display*
- *Supports VGA, Camera, WiFi, GPS, GPRS, 3G Functions through Modules*
- *Supports Linux2.6 and WinCE 6.0*

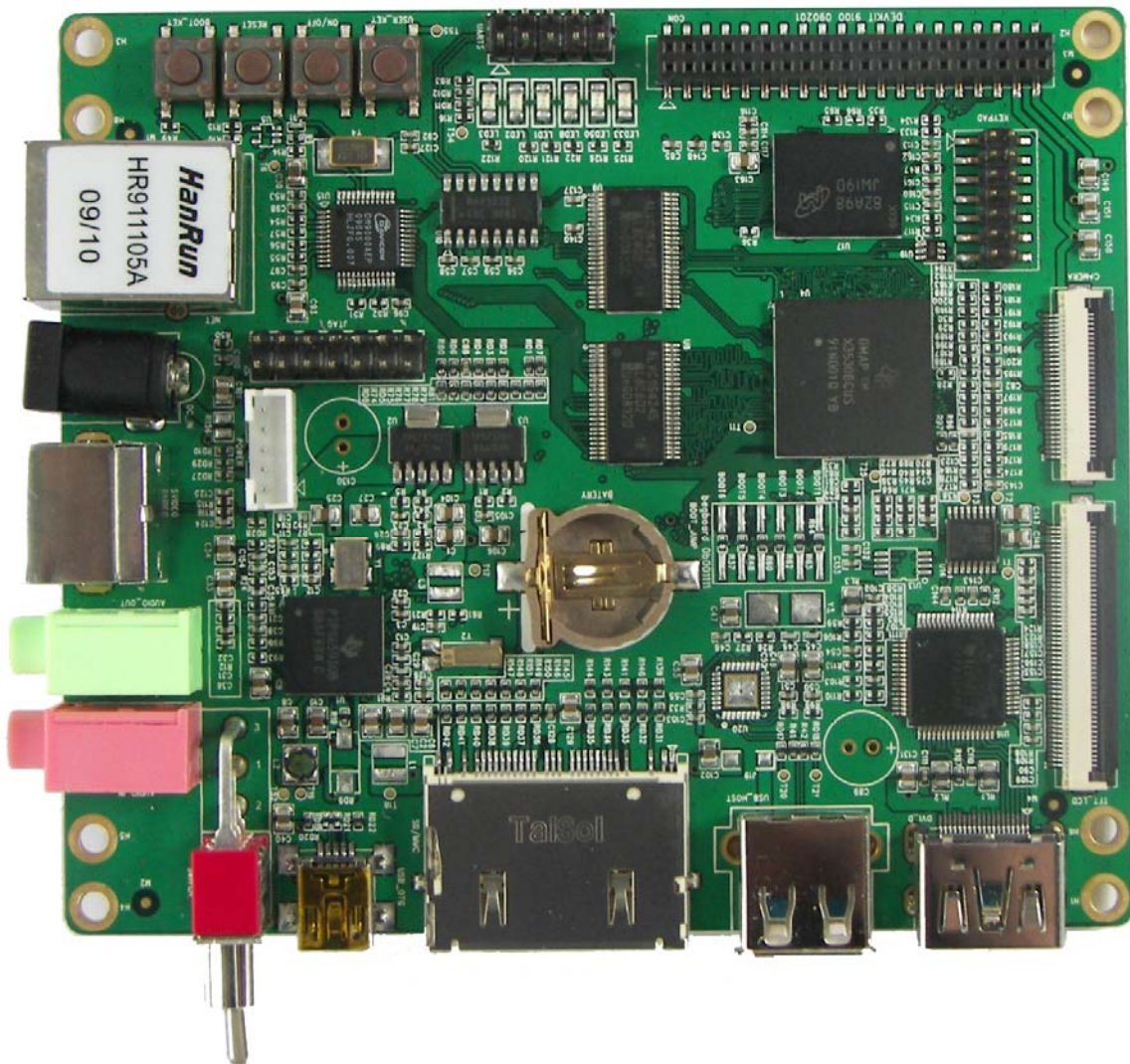

### ***Overview***

Embest DevKit8000 Evaluation Kit is an ideal hardware and software platform for OMAP35x processor development, it is a complete development system accelerating time to market for OEMs building portable handheld, multimedia, medical instrument or embedded devices. The platform features an OMAP3530 Application Processor with supporting peripheral hardware and a production-quality Windows® Embedded CE 6.0 BSP; it can also run Linux 2.6.28, a demo of Google Android OS and Angstrom (GPE) released version is also included in the product.

### ***The Evaluation Board***

The DevKit8000 Evaluation Board is a high-performance compact board based on TI OMAP3530 processor (ARM Cortex-A8 Core ~600MHz paired with a TMS320C64x+ DSP ~430MHz), with 256MByte DDR SDRAM and 256MByte NAND Flash as well as a USB OTG interface supporting 480Mbps speed. The board exposes many other hardware interfaces including RS232

serial port, LCD/TSP, DVI-D, S-Video, Ethernet, SD, keyboard, camera, SPI, I2C and JTAG.

DevKit8000 Evaluation Board provides a wide range of video output interfaces (LCD, DVI-D, S-Video).

- TFT LCD (24-bit True Color, Resolution supporting up to 2048\*2048)
- DVI-D for connecting to digital computer monitor (Supports 720p, 30fps signals output)
- S-Video out for connecting to TV for NTSC or PAL video output

The DevKit8000 Evaluation Board is able to support WinCE OS and Linux. The WinCE OS software package includes WinCE6.0 BSP and drivers of which many are in source code; and the Linux BSP contains the compile tools, the source code of the boot loader and the Linux 2.6.28 and the device drivers. The board has two methods to boot the system and you can boot the board from either SD card or NAND Flash. Embest also provides the demo of Google Android OS and Angstrom (GPE) for user experience.

### The Evaluation Kit

The DevKit8000 Evaluation Kit includes the DevKit8000 evaluation board and all necessary accessories to help users start their design of multimedia applications. It is preloaded with Linux OS in NAND flash and WinCE OS in SD card. User can display the system by using a 4.3" or 7" TFT LCD and Touch screen or using a DVI-D monitor with an HDMI to DVI-D cable, or using a TV for NTSC or PAL video display. The USB OTG can be used as USB Host function with a Mini-A to Standard-A cable, or as USB Device function with a Mini-B to Standard-A cable. The board has audio and video codecs, with the support of DSP, H.264, MPEG4, CIF, and D1 media formats can all be supported. Along with the kit, Embest provides user manual, schematic drawing and datasheet documents to help customers better understand and use the kit.

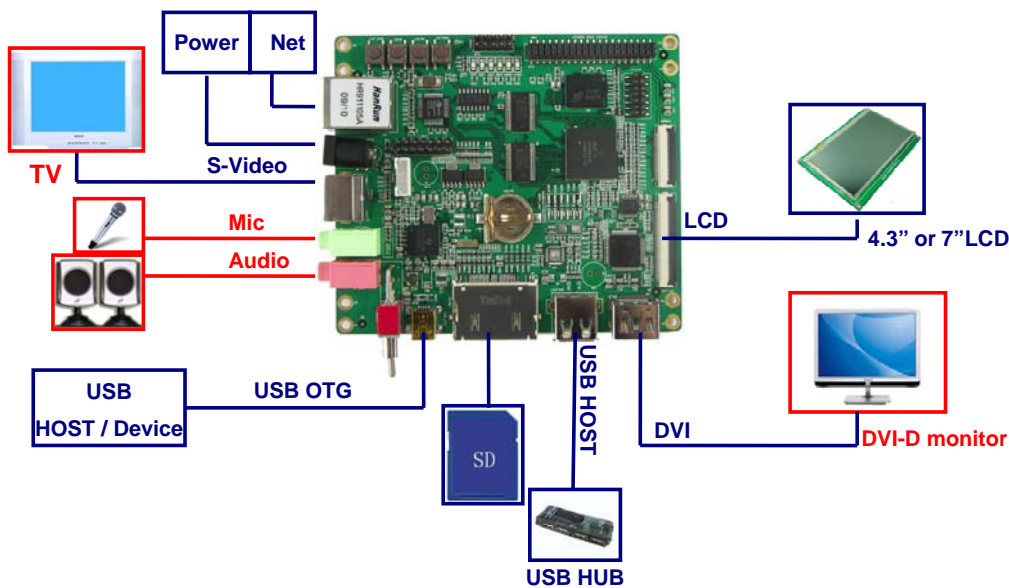

Indicates the device won't be provided in the Kit, user must prepare it themselves if they need.

Indicates the device or cable will be provided in the Kit by Embest.

The DevKit8000 Evaluation Kit for WinCE has eBook functions, supporting Microsoft office applications such as WORD, EXCEL, PDF and TXT for viewing documents; it also has Power Management function, which can manage the Backlight, batter and achieve the sleep/wake-up function; it also has synchronizing function, which enables data synchronization between your PC and the kit; it would also be a media player which is capable of playing audio or video files like MP3 or MP4.

The DevKit8000 Evaluation Kit for Linux has provided some demos for user. Google Android OS is a very good open-source mobile phone operating system; and Angstrom (GPE) makes a stable and user-friendly distribution for embedded devices like handhelds, user can use the demo to experience the charm of OMAP. Embest will provide the source code for Linux 2.6.28 and the file system; user can develop the driver and the applications with the board.

Additionally, Embest offers various modules for Devkit8000 including VGA, WiFi, Analog Camera, GPS, GPRS, 3G (CDMA2000 or WCDMA standards) and Digital Camera modules which greatly extends the functions of the board and would be flexible for customer selection to meet their own needs.



Cross Ethernet cable



USB cable



Serial cable



S-video cable



HDMI to DVI-D cable

A to Mini-A, A to Mini-B

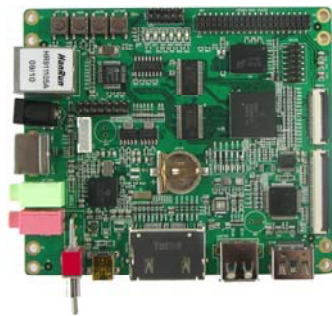

DevKit8000 Evaluation board



5V@2A Power adapter



USB HUB



SD card

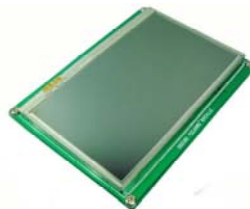

4.3" or 7" LCD+Touch Screen



Touch Pen



CD

DevKit8000 Evaluation Kit (Complete Configuration)

## Characteristic Display

### Android system support

The DevKit8000 can support Android which is a software platform and operating system for mobile devices, based on the Linux kernel, developed by Google and later the Open Handset Alliance. The board can run various applications based on Android. It supports 4.3" and 7" TFT LCD display and touch panel function. It can use the built-in audio player of Android to play kinds of audio files and transfer data through SD card or USB OTG.



### Angstrom system support

DevKit8000 can display Angstrom system on a DVI\_D monitor running 720p videos at 30fps. DevKit8000 can use various software of Angstrom to implement file editing, internet surfing, audio and video files playing and graphics editing and more other functions. User can use USB mouser to operate on Angstrom system.



### DVSDK software Package

DevKit8000 supports DVSDK package which includes following functions:

- Supports 2D/3D graphics acceleration
  - Supports DSP codec
- (Supports audio and video hardware decoding)
- Supports S-Video output



## **Hardware Features**

---

The OMAP3530 processor is based on the market's first broad offering of the ARM® Cortex™-A8 core to provide an unprecedented combination of laptop-like performance at handheld power levels in a single chip. With more than four times the processing power of today's 300MHz ARM9 devices, the superscalar 600 MHz Cortex-A8 core is integrated into four new OMAP35x applications processors. The processor offer a variety of combinations of the Cortex-A8 core, multimedia- rich peripherals, OpenGL® ES 2.0 compatible graphics engine, video accelerators and TMS320C64x+ DSP core.

The DevKit8000 Evaluation board is based on OMAP3530 processor and takes full features of the processor. This board is characterized as follows:

### Processor

- OMAP3530 processor (pin-to-pin compatible with OMAP35x families)
- 600-MHz ARM Cortex™-A8 Core
- 412-MHz TMS320C64x+™ DSP Core
- Integrated L1 memory for ARM CPU (16kB I-Cache, 16kB D-Cache, 256kB L2) and On-Chip memory (64kB SRAM, 112kB ROM)

### Memory

- 256MByte DDR SDRAM, 166MHz
- 256MByte NAND Flash, 16bit

### Audio/Video Interfaces

- A 4 line S-VIDEO interface
- An HDMI interface (High Definition Multimedia Interface)
- A audio input interface
- A two-channel audio output interface
- A TFT LCD interface, 24-bit true color, resolution supporting up to 2048\*2048
- 4 line Touch Screen

### Data Transfer Interface

- Serial port:
  - 1 x 3 line serial port, RS232 voltage
  - 1 x 5 line serial port, TTL voltage
- USB port:
  - 1 x USB2.0 OTG, High-speed, 480Mbps
  - 1 x USB2.0 Host, High-speed, 480Mbps
- SD port:
  - 1 channel SD port, support 3.3V and 1.8V logic voltage
  - 1 channel SD port, support 1.8V logic voltage
- Ethernet: 10/100Mbps, RJ45 connector
- 1 channel McSPI Interface (Multichannel Serial Port Interface)
- 1 channel McBSP interface (Multi-Channel Buffered Serial Port)
- 1 channel I2C interface
- 1 channel HDQ interface (HDQ/1-Wire)

### Input Interface

- 1 Camera interface (support CCD or CMOS camera)
- 6\*6 keyboard interface
- One 14-pin JTAG interface
- One BOOT button
- One RESET button
- One USER button
- One ON/OFF button

### Mechanical Parameters

- Dimensions: 110 mm x 95 mm
- Input Voltage: +5V
- Power Consumption: 0.5A @ 5V
- Temperature Range: -40 °C ~ 85 °C (Chip supported)
- Humidity Range: 20% ~ 90%

***Interface Introduction***

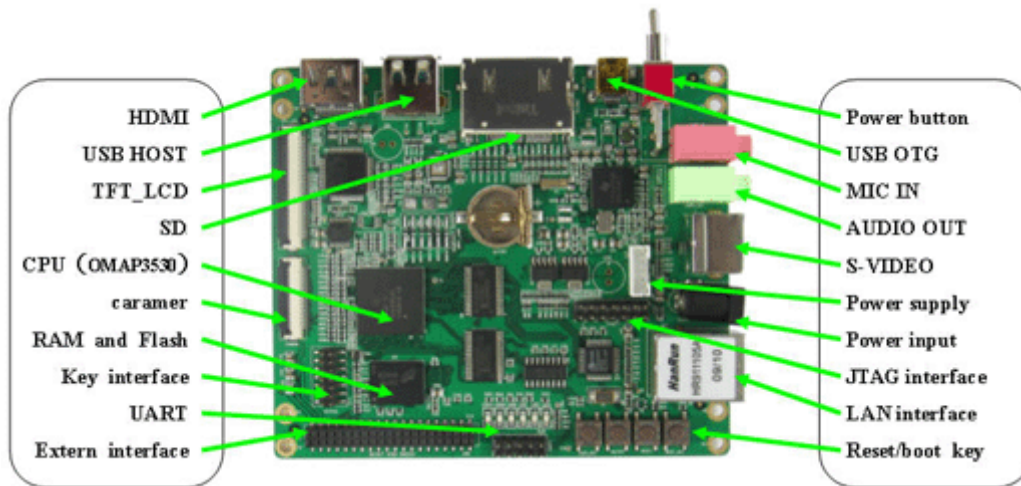



Function Block Diagram

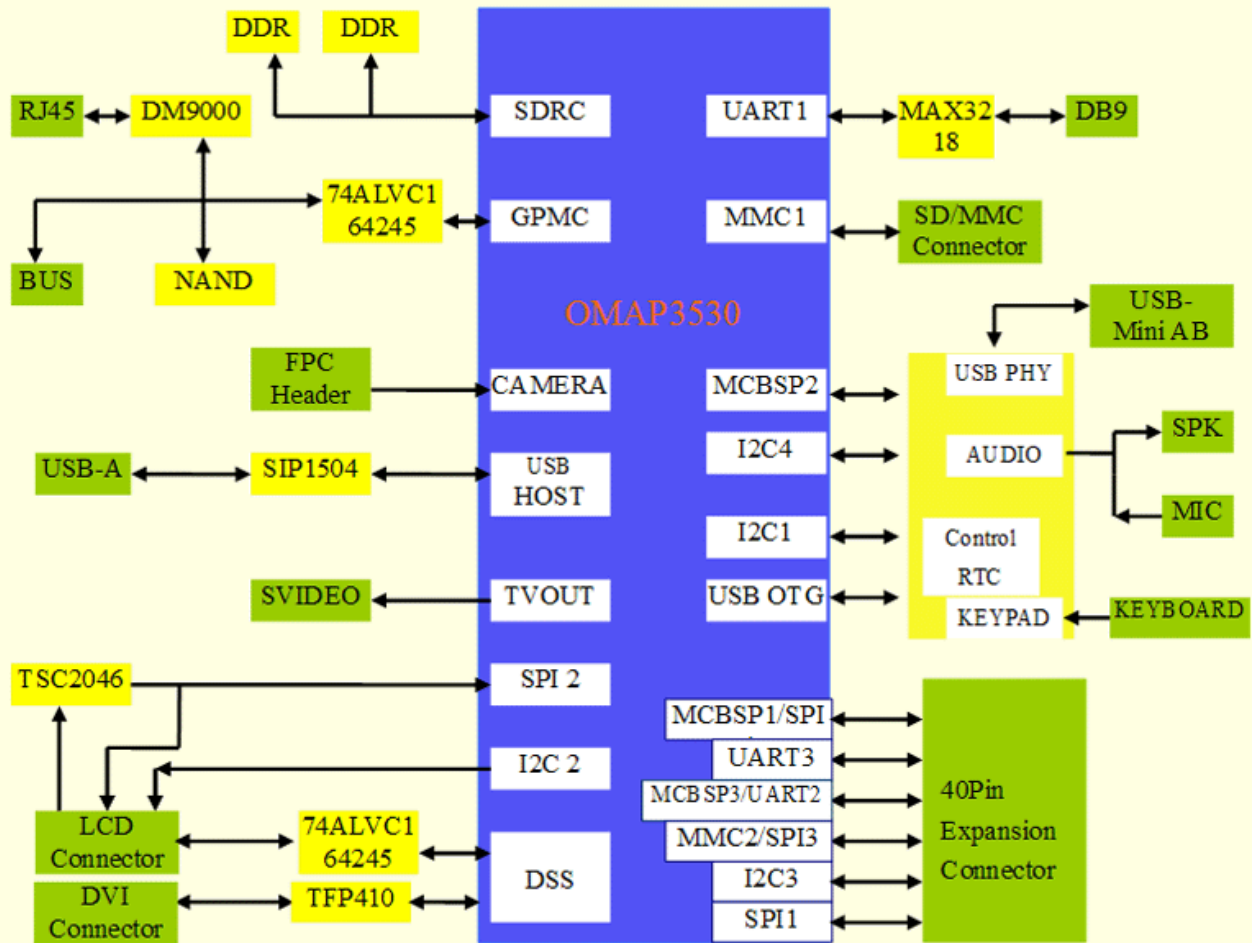

Note:

- Indicates the chips on the board.
- Indicates the connectors on the board.
- Indicates the CPU module on the board.

**Software**

The DevKit8000 Evaluation board provides Window CE 6.0.net BSP and Linux 2.6.28 BSP, steady-going drivers, many of which are all in source code. Please refer to below table.

OS	Item	Feature	Description
Linux	Boot	Version	X-loader-1.41 U-boot 1.3.3
		Boot Mode	Boot Linux from SD card, NAND Flash or Ethernet
		Image update	Support updating image from SD card or Ethernet
	Kernel and drivers	Version	Linux 2.6.28
		File System Format	ROM/CRAM/EXT2/EXT3/FAT/NFS/JFFS2/UBIFS
		Driver	UART, RTC, NET, Nand, LCD, Touch Screen, SD, USB OTG, DVI, Keypad, LED
	File System	File System Format	Ramdisk File System, UBI File System
		function	Provided Lib (ALSA -lib, tslib, glibc), udev support
	Demo	Angstrom	Audio (XMMS), network (firefox), graphics editor (gimp) and document processing software (Abiword)
		Android	Google developed a platform based on Linux open-source mobile phone operating system
DVSDK		Support MPEG4, MPEG2, H264, mp3, aac audio/video formats and Codecs	
WinCE	Boot	Version	x-load-1.41, eboot
		Boot Mode	Boot WINCE from SD card, NAND Flash or Ethernet
		Image update	Support updating image from SD card or Ethernet
	System	System Characteristics	KITL kernel debug, Reboot, Watchdog, RTC
		Driver	display driver (DVI, TFT LCD)
			SD card, Keyboard, McSPI, McBSP, Audio, NET, NLED, USB OTG
		System function	Power Management (backlight drive, battery-driven, sleep/ wake-up function)
			Hive registry support
			ROM file system support
		Software features	Mediaplayer 9.0, Word and Internet Explorer 6.0 .NET Compact Framework 3.5

**Order Information**

Order No.	T6010074 (Standard Configuration)
Item	DevKit8000 Evaluation Board
Hardware	<ul style="list-style-type: none"> <li>• One DevKit8000 Evaluation board</li> <li>• One 2MB SD card</li> <li>• One Serial cable (IDC10-to-DB9)</li> <li>• One 5V@2A Power adapter</li> </ul>
Software and Documents	<ul style="list-style-type: none"> <li>• Documents (user manual, schematic drawing, Datasheet)</li> <li>• WinCE.net 6.0 BSP</li> <li>• Linux 2.6.28 BSP</li> </ul>
Order No.	T6010075 (Complete Configuration)
Item	DevKit8000 Evaluation Kit
Hardware	<ul style="list-style-type: none"> <li>• One DevKit8000 Evaluation board</li> <li>• One 4.3" or 7" TFT LCD (With Touch panel)</li> <li>• One 2MB SD card</li> <li>• One Serial cable (IDC10-to-DB9)</li> <li>• One 5V@2A Power adapter</li> <li>• One Touch Pen</li> <li>• One USB cable (Type A Male to Type Mini-B Male)</li> <li>• One USB cable (Type A Female to Type Mini-A Male)</li> <li>• One USB HUB</li> <li>• One Cross Ethernet cable</li> <li>• One HDMI to DVI-D cable</li> <li>• One S-Video cable</li> </ul>
Software and Documents	<ul style="list-style-type: none"> <li>• Documents (user manual, schematic drawing, Datasheet)</li> <li>• WinCE.net 6.0 BSP</li> <li>• Linux 2.6.28 BSP</li> </ul>
Options	<ul style="list-style-type: none"> <li>• CAM8000-A Analog camera module</li> <li>• VGA8000 VGA module</li> <li>• CAM8100-U Digital camera module</li> <li>• WF8000-U WiFi module</li> <li>• GPS8000-S GPS module</li> <li>• GPRS8000-S GPRS module</li> <li>• CDMA8000-U USB CDMA module</li> <li>• WCDMA-U USB WCDMA module</li> <li>• XDS100v2 Emulator</li> <li>• Mounting bracker</li> </ul>
Price	Please contact us.

**Embest Info&Tech Co., LTD.**

Room 509, Luohu Science&Technology Building,  
 #85 Taining Rd., Shenzhen, Guangdong, China 518020

Tel: +86-755-25635656/25635626

Fax: +86-755-25616057

Email: [market@embedinfo.com](mailto:market@embedinfo.com)

<http://www.embedinfo.com> <http://www.armkits.com>